



WH L4 Lever Hoist with Shipyard Hooks

The Hackett WH L4 lever hoist c/w shipyard hooks meets and exceeds the requirements of the following international standards:

British and European Standard BS EN13157:2004 + A1:2009

American Standard ASME B30.21-2014

Australian Standard AS1418.2-1997

South African Standard SANS 1636:2-2007

NORSOK R-002: 2017.

The design and specification of the William Hackett WH L4 lever hoist c/w shipyard hooks includes:

- **WORKING LOAD LIMIT:** 1.6t and 3.2t.
- **LIGHT LOAD CAPABILITY:** the WH L4 c/w shipyard hooks is tested and certified at 2% of the lever hoist rated capacity.
- **TWIN PAWL:** double safety; fitted as standard.
- **SAFETY LATCHES:** the hoist top and bottom hooks are fitted with heavy duty cast steel latches.
- **HOOK HOUSING:** secured with socket head cap screws/hex head bolts and nyloc locking nuts to allow full inspection.
- **FLEETING/CROSS HAULING:** the WH L4 lever hoists c/w with shipyard hooks are tested and certified for fleeting or cross hauling applications up to 45° from the vertical without deration.
- **LOAD CHAIN:** the hoists are fitted with load chain that fully complies with international standard BS EN818-7 Grade T (8).
- **TEMPERATURE RANGE:** -20°C to +120°C.
- **PROOF TESTED:** hoists are proof tested to 1.5 times the Working Load Limit.
- **OVERLOAD LIMITER:** available as an option upon request.
- **MANUFACTURED AND PROOF TESTED** in the U.K.



For use in shipyards, fabrication facilities, upset welding, pulling angle iron and other applications.

Hooks on standard lever hoists are NOT constructed to load the hook tip against steel plate edges when used in shipyards, fabrication facilities and where pulling angle iron and upset welding are regular applications.

If the standard lever hoist top and bottom hooks are used in this way the hooks will need to be replaced due to deformation. A lever hoist is often used in operations where the hook tip needs loading to pull together objects which will increase the element of user risk and can ultimately cause the operator to damage the hoist.

To mitigate this issue William Hackett has introduced the option of shipyard hooks to the L4 lever hoist which are specifically designed to perform these types of operation. The William Hackett L4 lever hoist fitted with shipyard hooks allows the user to hook against plate edges meaning the hooks will not become deformed when used within the marked working load limit.

Specifications

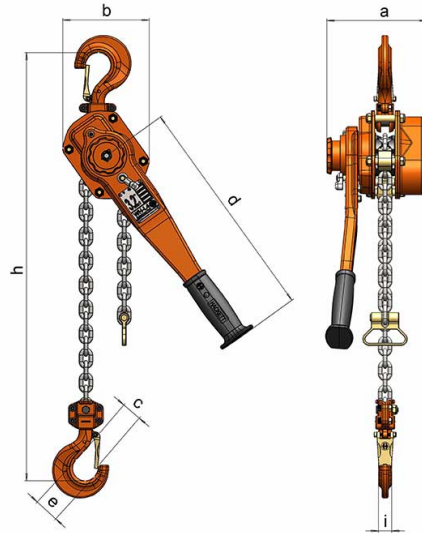

Part Code	WLL tonnes	No. of Falls	Load Chain mm	a mm	b mm	c mm	d mm	e mm	h mm	i mm	Mass Kg 1.5m HOL	Extra Weight per m kg
033.163.SY	1.6	1	7.2 x 21	165.5	141.0	52.0	415.0	33.0	350.0	20.0	9.6	1.1
033.323.SY	3.2	1	10 x 30	194.5	178.0	61.9	415.0	42.5	420.0	24.8	15.5	2.2



William Hackett

William Hackett Lifting Products Ltd Oak Drive, Lionheart Enterprise Park, Alnwick, Northumberland NE66 2EU
 Email: liftingsales@williamhackett.co.uk Tel: +44 (0)1665 604200 Fax: +44 (0)1665 604204

