



WH L4 Compact Lever Hoist

The Hackett WH L4 250kg and 500kg lever hoist meets and exceeds the requirements of the following international standards:

British and European Standard BS EN13157:2004 + A1:2009

American Standard ASME B30.21-2014

Australian Standard AS1418.2-1997

NORSOK R-002: 2017 (except for overload limiter).

The design and specification of the William Hackett WH-L4 compact lever hoist includes:

- **WORKING LOAD LIMIT RANGE:** 250kg and 500kg.
- **LIGHT LOAD CAPABILITY:** the WH L4 compact lever hoist is tested and certified at 2% of the lever hoist rated capacity.
- **TWIN PAWL:** double safety; fitted as standard.
- **SAFETY FACTOR:** 4:1.
- **SAFETY LATCHES:** the WH L4 compact lever hoist top and bottom hooks are fitted with heavy duty cast steel latches. The latch and hook tips are integrated creating a strong and robust hook closure.
- **OVERLOAD INDICATOR MARKS:** the WH L4 compact lever hoist top and bottom hooks have, as part of the hook forging, overload indicator marks either side of the hook throat.
- **LOAD CHAIN:** the WH L4 compact lever hoists are fitted with load chain that generally complies with international standard BS EN818-7. Grade T (8).
- **ROBUST END STOP:** Ergonomically designed load chain end stop allows the operative to secure a firm grip when using the end stop to adjust the chain.
- **COMPACT LEVER HOISTS:** supplied with a hard wearing belt bag carry case.
- **TEMPERATURE RANGE:** -20°C to + 120°C.
- **PROOF TESTED:** every hoist is proof tested to 1.5 times the Working Load Limit.
- **MANUFACTURED AND PROOF TESTED** in the U.K.



SPECIFICATION AND DIMENSIONS

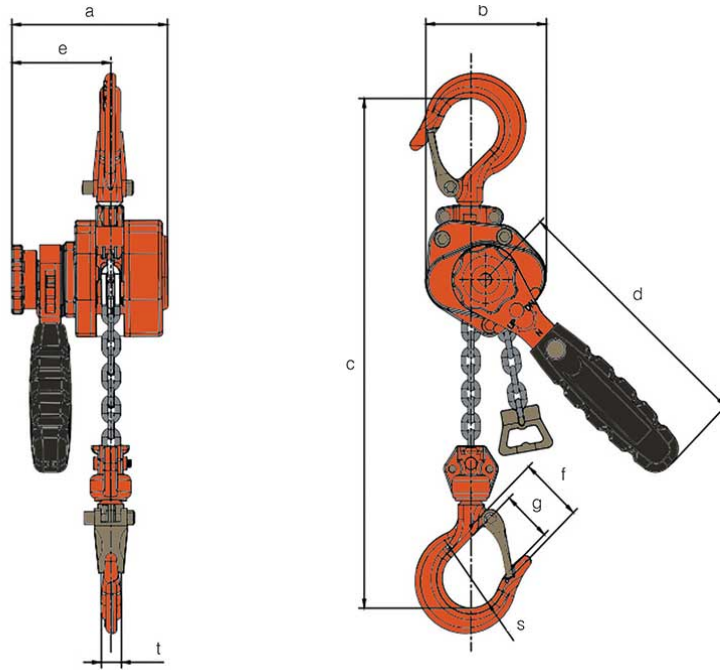

Part Code	WLL tonnes	No. of Falls	Load Chain mm	Standard Lift m	A mm	B mm	C mm	D mm	E mm	F mm	G mm	S mm	T mm	Mass kg
032.025	0.25	1	3.2 x 9	1.5	90	68	200	150	56	35.5	20	32	11	1.6
032.050	0.50	1	4.3 x 12	1.5	98	81	250	172	62	42	21	34.5	12.5	2.6



William Hackett

William Hackett Lifting Products Ltd Oak Drive, Lionheart Enterprise Park, Alnwick, Northumberland NE66 2EU
 Email: liftingsales@williamhackett.co.uk Tel: +44 (0)1665 604200 Fax: +44 (0)1665 604204

